

## SERVICE ADVANTAGE

### After-sales service

Any problems from the product, we will reply customer within 24 hours and problem handling less than 48 hours.

### Free-training service

New customer can have 7 days training for free.



AccuBal Intelligent Machinery Co.,Ltd

# Our mission

Best service to customers, achievement of the global industry intelligence

**AccuBal Intelligent Machinery Co.,Ltd**

Address: No.31 East Shunye Road,Xingtan town,Shunde District,Foshan city,China

Phone:+86 757 2981 1151 Fax:+86 757 2981 1152 E-mail:marketing@abscale.net

[www.accubalscale.com](http://www.accubalscale.com)



## About us

AccuBal is a professional manufacturer of multihead weighers, provides professional weighing solution to clients at the same time.

Located in Guangdong Intelligent manufacture base (**Guangdong Shunde**) which is technology front. Plant construction area at least **20000 square meters** with registered capital of **20 million RMB**.

Company owns a group of experienced technician and engineers, possesses the integrated ability including R&D, manufacturing, sales installing and debugging, technical training, post-sale service for products, has the ability of independent intellectual property program to develop SCM program, provides excellent quality products and solutions to clients by its leading technology. The products were passed by **the China metrology certification (CMC) and EU international certification (CE)**.

AccuBal mission: Best service to customers, achievement of the global industry intelligence.

We follow quality policy "The quality of products to survive and to the quality of service development" to improve products intelligence service at the same time. Innovative business philosophy, strict management model, make the company's products all over the world. AccuBal committed to become a century enterprise, provides efficient service program to clients of automatic weighing and metering.

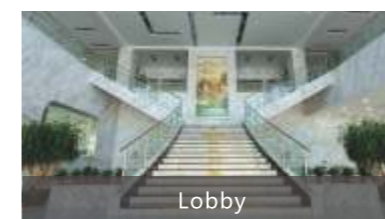

Lobby



Assembly line



CNC Workshop



Metal pressing workshop

## Company history

**On 2007**

highspeed company was established, the main products are multihead weigher and linear weigher.

**On 2010**

due to the change of the company's factory address, the company was officially renamed Solid intelligent machinery Ltd.

**On 2013**

was established in Guangdong Foshan Shunde district.

**On 2015**

headquarters located in Guangdong Foshan Shunde high-tech industrial zone, covering area more than 10000 square meters, Research and development, production, marketing and service levels to rise again to a whole new level. Production capacity can achieve 2000 sets equipment per year.

**On 2016**

incorporated "Guangdong Accubal Intelligent machinery Co.,Ltd". Registered capital 20 million.

**On 2018 and future**

accelerate the pace of innovation.

# New version economic multihead weigher



## Application sample:

Puffed food, roasted nuts & seeds, potato chips, candy, sweet dumplings, biscuits, pasta, herbal pieces, pet food, frozen food, hardware ect.....



## Main Feature:

- Strength of standard combination weigher: wide range of application, high price competitiveness, reliable performance.
- 10.4 inch color display, lots of language can be chosen.
- Speed and amplitude can be adjusted in operation process.
- Weigh hopper followed by discharge, effectively prevents blockages.
- Amplitude of each linear feeder can be adjusted separately.
- 99 of present programs are preprogrammed in stock.

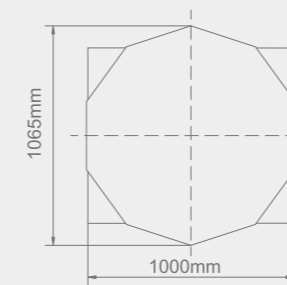

10 head 1.3L

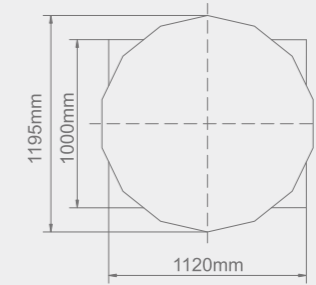
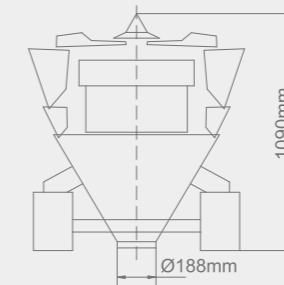

14 head 1.3L

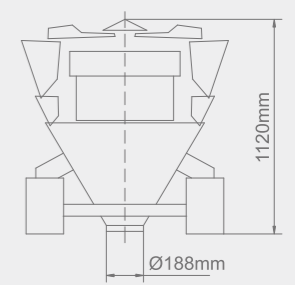

## Specification:

Order Number	AB-E10	AB-E10	AB-E14	AB-E14
Item No.	2C-1XP	2C-3XP	2C-1XP	2C-3XP
Hopper No.	10	10	14	14
Max.weighing speed (WPM)	≤65BPM	≤65BPM	≤100BPM	≤100BPM
Average Tolerance	0.5g~1.5g	0.5g~1.5g	0.5g~1.5g	0.5g~1.5g
Hopper Volume	1.6Liter	3Liter	1.6Liter	3Liter
Max.single discharge	3000ml	6000ml	3000ml	6000ml
Single weigh	20g-1000g	20g-1000g	20g-1000g	20g-1000g
Single Max length	≤80mm	≤120mm	≤80mm	≤120mm
Water proof	IP64/IP65 Optional		IP64/IP65 Optional	
Preset number program	99		99	
Display	10.4 inch TFT colour screen		10.4 inch TFT colour screen	
Power	Single AC 220±10% ; 50/60Hz;1.9KW		Single AC 220±10% ; 50/60Hz;3.6KW	

# Stainless steel actuator weigher



## Application sample:

Puffed food, roasted seeds& nuts, potato chips, candy, sweet dumpling, biscuits, pasta, herbal pieces, pet food, frozen food, hardware etc.....



## Main Feature:

- All hoppers adopt without spring design to reduce noise in operation process.
- All stainless steel external design, high-end appearance, easy to clean.
- The waterproof reaches IP65 level with standard anti-condensation design, it still can effectively running even in complex environment.

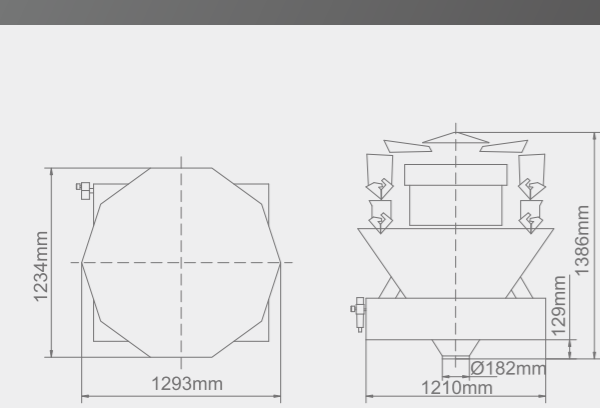

10 head



## Application sample:

Puffed food, roasted seeds& nuts, potato chips, candy, sweet dumpling, biscuits, pasta, herbal pieces, pet food, frozen food, hardware etc.....



## Main Feature:

- New Upgraded software with more than 20 improvements.
- 10% higher performance in practical application.
- Canbus architecture with modular control units.
- Complete stainless housing machine by high quality SUS.
- Individual discharge chute to keep the materials from rotating and drop faster.

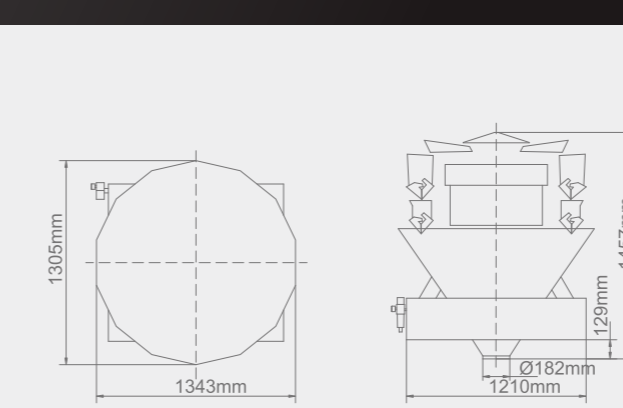

14 head



## Specification:

Order Number	AB-E10	AB-E10
Item No.	2C-1X	2C-3X
Hopper No.	10	10
Max.weighing speed (WPM)	≤75BPM	≤75BPM
Average Tolerance	0.5g~1.5g	0.5g~1.5g
Hopper Volume	1.6Liter	3Liter
Max.single discharge	4000ml	5000ml
Single weigh	20g-1000g	20g-3000g
Single Max length	≤100mm	≤100mm
Water proof	IP66	
Preset number program	99	
Display	10.4 inch TFT colour screen	
Power	Single AC 220±10% ; 50/60Hz; 3.6KW	

## Specification:

Order Number	AB-E14	AB-E14
Item No.	2C-1X	2C-3X
Hopper No.	14	14
Max.weighing speed (WPM)	≤120BPM	≤120BPM
Average Tolerance	0.5g~1.5g	0.5g~1.5g
Hopper Volume	1.6Liter	3Liter
Max.single discharge	4000ml	5000ml
Single weigh	20g-1000g	20g-3000g
Single Max length	≤100mm	≤100mm
Water proof	IP66	
Preset number program	99	
Display	10.4 inch TFT colour screen	
Power	Single AC 220±10% ; 50/60Hz; 3.6KW	

# 5. 5L/7.5L large capacity weigher



## Application sample:

Loose or leafy objects such as Mix salads ,been sprouts and frozen objects such as potato chips .



## Main feature:

- The design of large capacity hopper apply to the weighing solution of heavy and large volume materials.
- Superior waterproof performance, easy for cleaning and wire protection.
- Anti-condensation processing device and 7.5L hopper can solve effectively large capacity or heavy materials weighing solution.
- Speed of main vibration and amplitude can be dynamically adjusted by display.
- The feeding amount of conveyor can be controlled by analog signal.
- The newest 4G mainboard available to use the function of network, display with USB connector and automatic program updates.
- Wide angle camera can control the materials operation status of main vibration plate and linear plate.
- Waterproof level reaches standard IP65, easy for cleaning and wire protection.

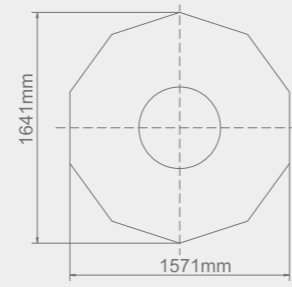
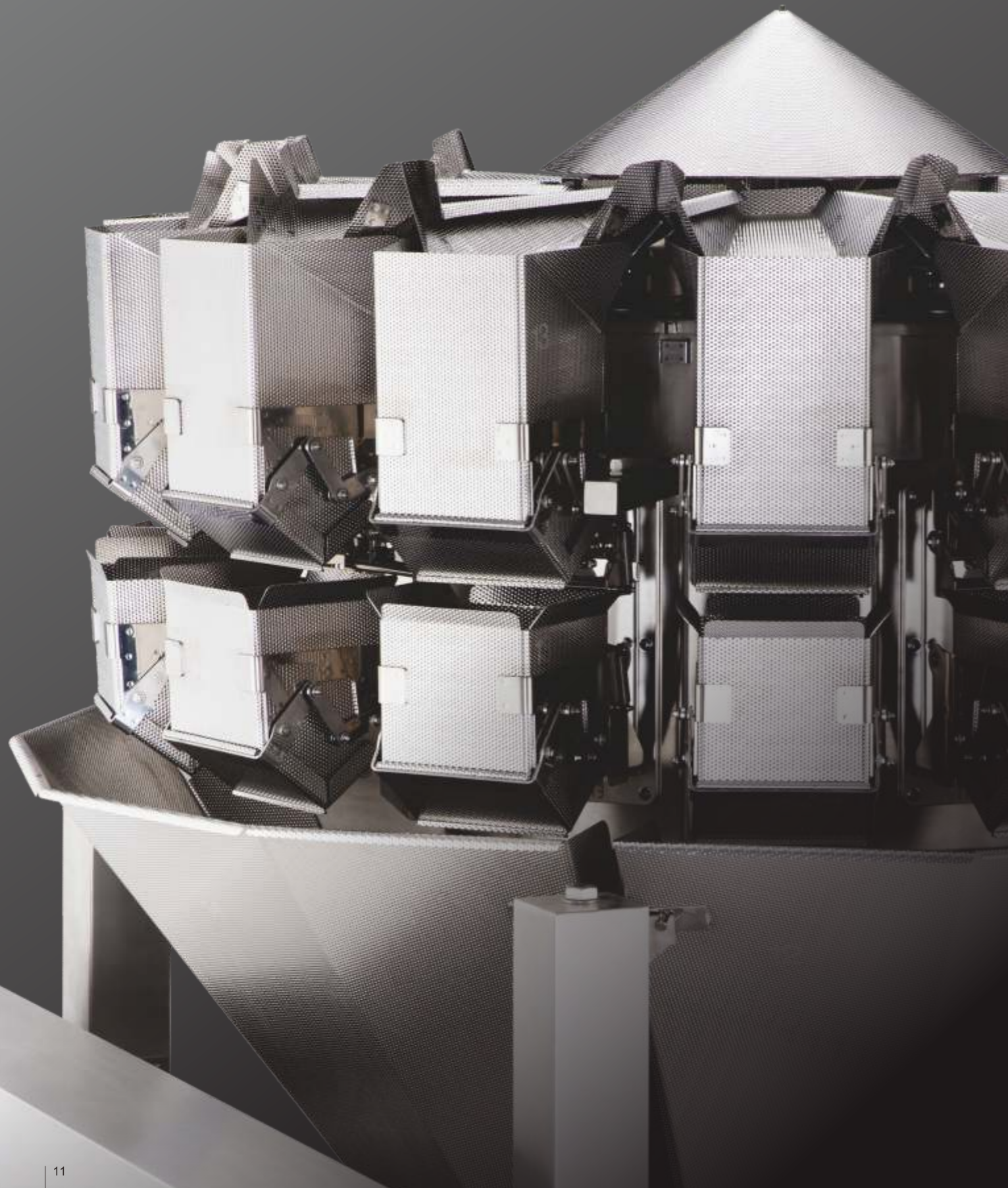

5.5L (10 heads)

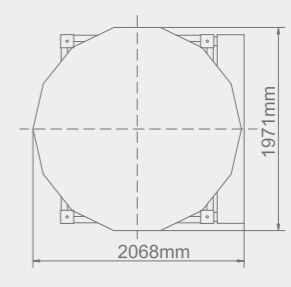

7.5L (14 heads)

## Specification:

	AB-E10	AB-E14	AB-E14
<b>Order Number</b>	<b>AB-E10</b>	<b>AB-E14</b>	<b>AB-E14</b>
Item No.	2B-6Y	2B-6Y	4A-14X
Hopper No.	10	14	14
Max.weighing speed (WPM)	≤50BPM	≤70BPM	≤100BPM
Average Tolerance	3g~8g	3g~8g	3g~8g
Hopper Volume	5500ml	5500ml	7500ml
Max.single discharge	11000ml	11000ml	15000ml
Single weigh	100g-3000g	100g-3000g	100g-3000g
Single Max length	≤130mm	≤130mm	≤200mm
Water proof	IP64/IP65 Optional		IP65
Preset number program	99		99
Display	10.4 inch TFT colour screen		10.4 inch TFT colour screen
Power	单相 AC 220±10% ; 50/60Hz; 1.9KW	Single AC 220±10% ; 50/60Hz; 3.6KW	Single AC 220±10% ; 50/60Hz; 4.3KW

# 0.5L screw feeding weigher

## Application sample:

Spicy fish, Sour bean, Pickles, dried radish and other material with sauce ; jelly fish, poultry, meat.....etc which are processed with sause, materials not easy to move by vibration.



## Main feature:

- Screw feeding and scraper hopper for extra sticky products, also ensure the taste for pre-mixed food with sauce.
- Interchangeable hopper design enables easy maintenance and washdown.
- Optional extra sets of screw feeder for different products.
- Compact design minimize the footprint.
- By using belt conveyor, minimize the sticking on the traditional collecting chute.

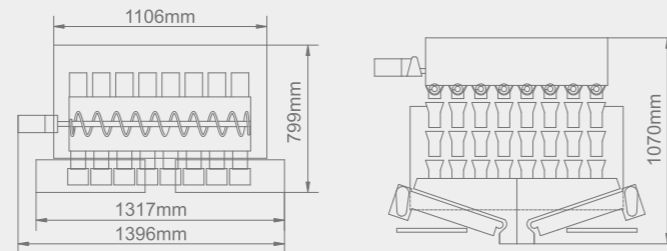

## Specification:

Order Number	AB-S8
Item No.	4A-12SF
Hopper No.	8
Max. weighing speed (WPM)	≤50BPM
Average Tolerance	0.5g~2.5g
Hopper Volume	500ml
Max. single discharge	1000ml
Single weigh	20g-500g
Single Max length	≤50mm
Water proof	IP54
Preset number program	99
Display	10.4 inch TFT colour screen
Power	Single AC 220±10% ; 50/60Hz; 1.9kw

# 1.5L screw feeding weigher



## Application sample:

Spicy fish, Sour bean, Pickles, dried radish and other material with sauce; jelly fish, poultry, meat.....etc which are processed with sause, materials not easy to move by vibration.

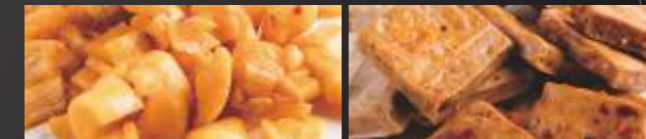

## Main feature:

- Screw feeding and scraper hopper for extra sticky products, also ensure the taste for pre-mixed food with sauce.
- Interchangeable hopper design enables easy maintenance and washdown.
- Optional extra sets of screw feeder for different products.
- Compact design minimize the footprint.
- By using belt conveyor, minimize the sticking on the traditional collecting chute.

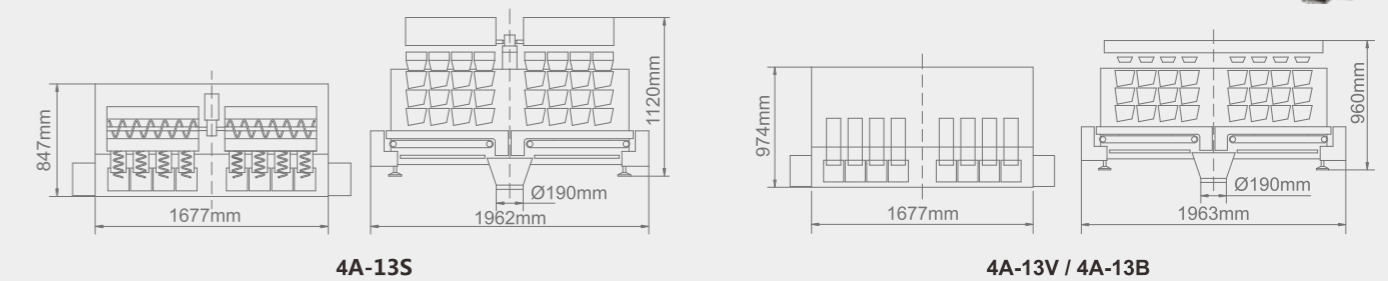

## Specification:

Order Number	AB-S8	AB-S8	AB-S8
Item No.	4A-13V	4A-13B	4A-13S
Hopper No.	8	8	8
Max. weighing speed (WPM)	≤40BPM	≤40BPM	≤40BPM
Average Tolerance	0.5g~3g	0.5g~3g	0.5g~3g
Hopper Volume	1500ml	1500ml	1500ml
Max. single discharge	3000ml	3000ml	3000ml
Single weigh	20g-1000g	20g-1000g	20g-1000g
Single Max length	≤90mm		
Water proof	IP66		
Preset number program	99		
Display	10.4 inch TFT colour screen		
Power	Single AC 220±10% ; 50/60Hz; 1.3KW		
Machine Category	Oscillation feeding pattern	Feeding by conveyor belt pattern	Screw feeding pattern

# SUPER PRECISION MICRO WEIGHER



## Application sample:

Tea/spices/herbs/tablets/capsules/ Capsules dried vegetable/fine and small weight products.



## Main feature:

- One of smallest and most precise multihead weigher in the world.
- Ultra-low target weights at high speed and unbelievable accuracy.
- Target weights from 0.5to 50g at speeds of up to 120 weighments per minute.
- Weight measures as low as 0.01g,target weights as low as 0.5g, accuracy as low as 0.03g.
- Applied 4.0 generation software advanced technologies,faster and more accurate than ever before, easier to clean and simpler to operate.

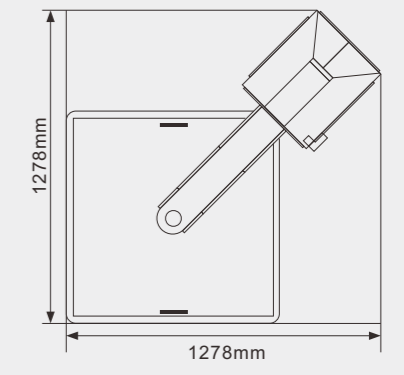
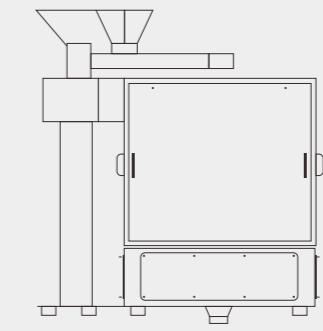
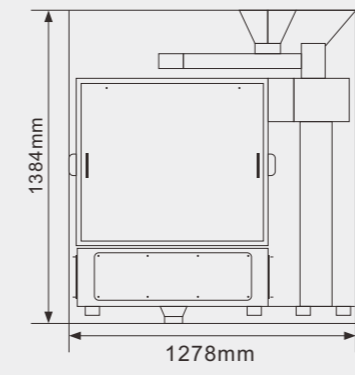
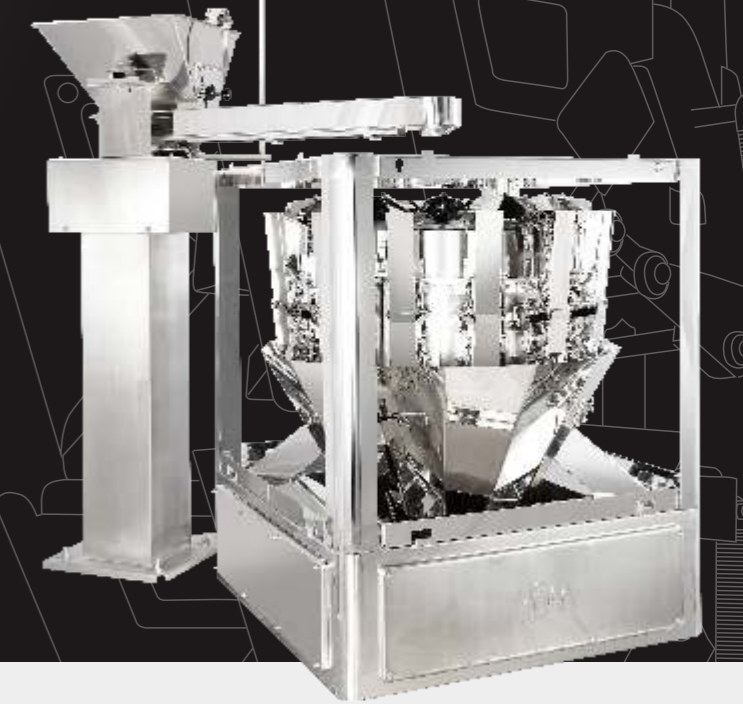

## Specification:

Order Number	AB-E14
Item No.	AB-E14-4A-18
Hopper No.	14
Max.weighing speed (WPM)	≤110BPM
Average Tolerance	±0.1g
Hopper Volume	100ml
Single weigh	20g-3000g
Single Max length	40mm±3mm
Water proof	IP50
Preset number program	99
Display	10.4 inch TFT colour screen
Power	Single AC 220±10% ; 50/60Hz; 3.6KW

# Mixed weigher

## Application samples:

- Apply to mix materials with well flowability.

## Main Feature:

- For mixing different products into one package or feeding multiple packers at the same time.

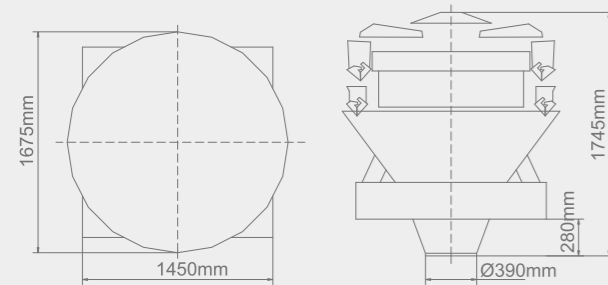
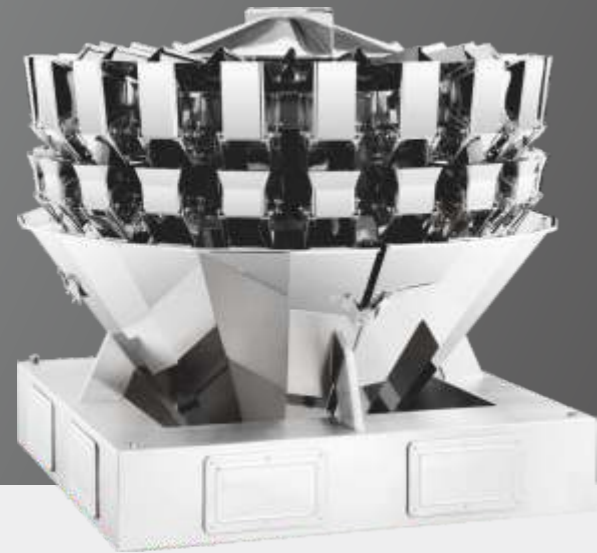
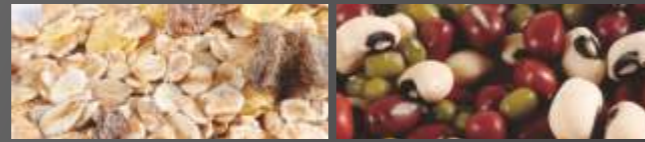

20 head

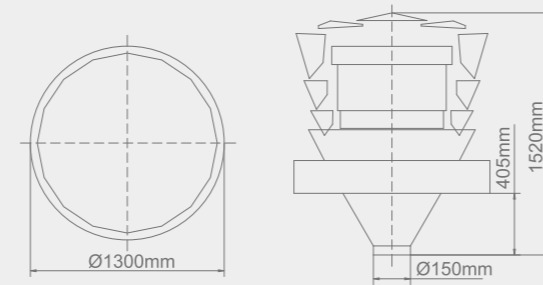

16 head

## Specification:

Order Number	AB-E20	AB-S16	AB-S18
Item No.	2B-3XM	4A-5XSM	4A-2XSM
Hopper No.	20	16	18
Max.weighing speed (WPM)	≤55BPM x 2sides	≤85BPM x 2sides	≤55BPM x 3sides
Average Tolerance	0.5g~2g	0.5g~1.5g	0.5g~1.5g
Hopper Volume	2500ml	1000ml	2000ml
Max.single discharge	5000ml x 2	2000ml x 2	4000ml x 3
Single weigh	20g-1000g	20g-500g	20g-500g
Single Max length	≤120mm	≤50mm	≤60mm
Water proof	IP64/IP65 Optional		
Preset number program	99		
Display	10.4 inch TFT colour screen		
Power	Single AC 220±10% ; 50/60Hz; 13.6kw	Single AC 220±10% ; 50/60Hz; 4.4kw	Single AC 220±10% ; 50/60Hz; 5kw

# Stick-shaped weigher

## Application sample:

Milk bar , food of bar-shaped, bar-shaped pet food, ect.....



## Main Feature:

- The insertion parts of feed bucket and weigh bucket can be removed, can be used as both normal and strip materials
- Independent chute designs can ensure materials falling vertically.
- By using vertical air cylinder, keep materials in order into the bag.

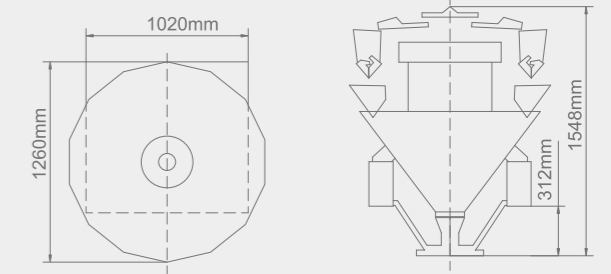

## Specification:

Order Number	AB-E14
Item No.	2B-3XT
Hopper No.	14
Max.weighing speed (WPM)	≤60BPM
Average Tolerance	0.5~1.5g
Hopper Volume	750ml
Max.single discharge	1500ml
Single weigh	20-1000g
Single Max length	≤120mm
Water proof	IP64/IP65 Optional
Preset number program	99
Display	10.4 inch TFT colour screen
Power	Single AC 220±10% ; 50/60Hz;3.6KW



# Full Automatic Packing System



- 1** Feeder
- 2** Acclivitous conveyor
- 3** Platform
- 4** Multihead weigher
- 5** VFFS

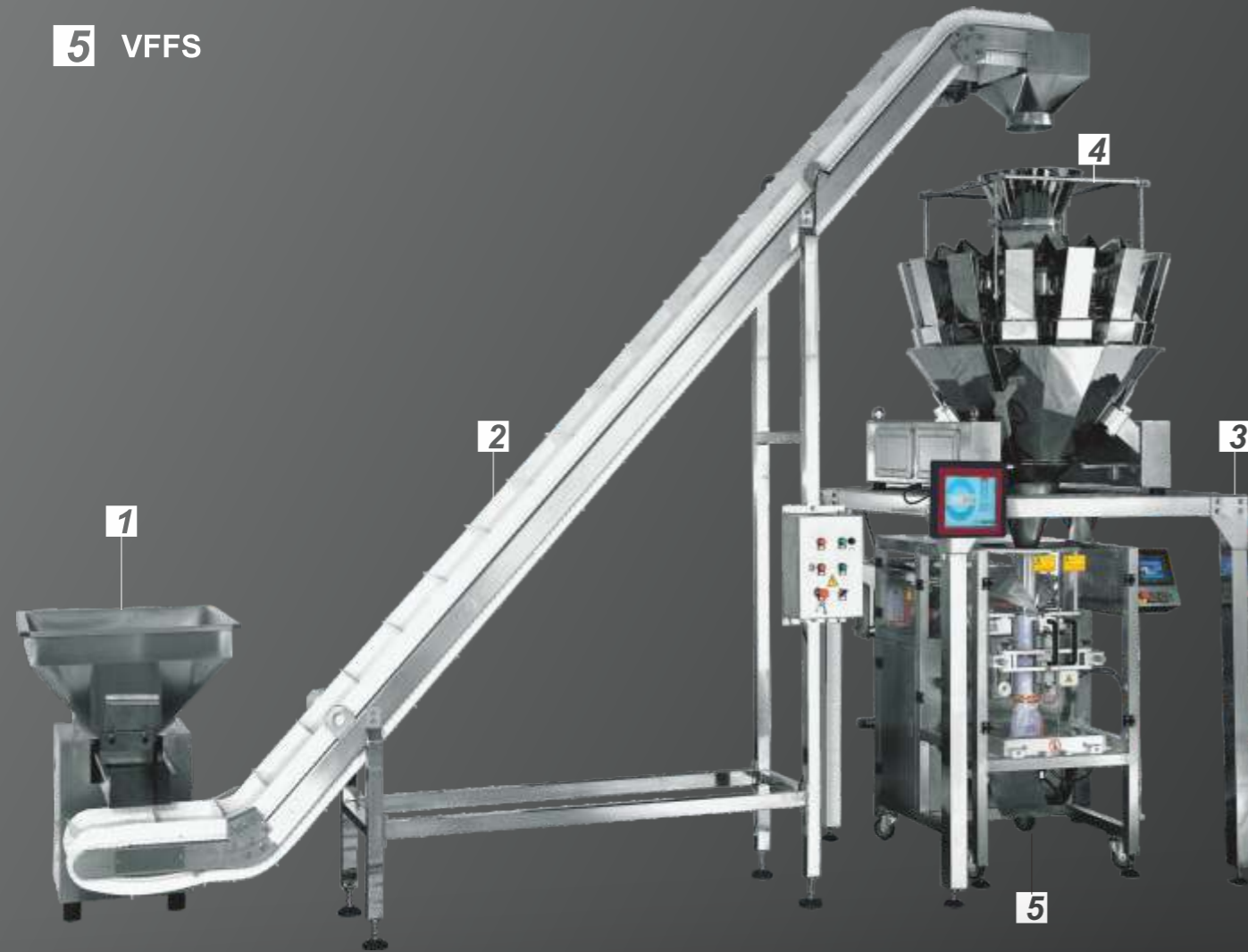

# Spare Parts

